

COMPONENT LOCATION DIAGRAM

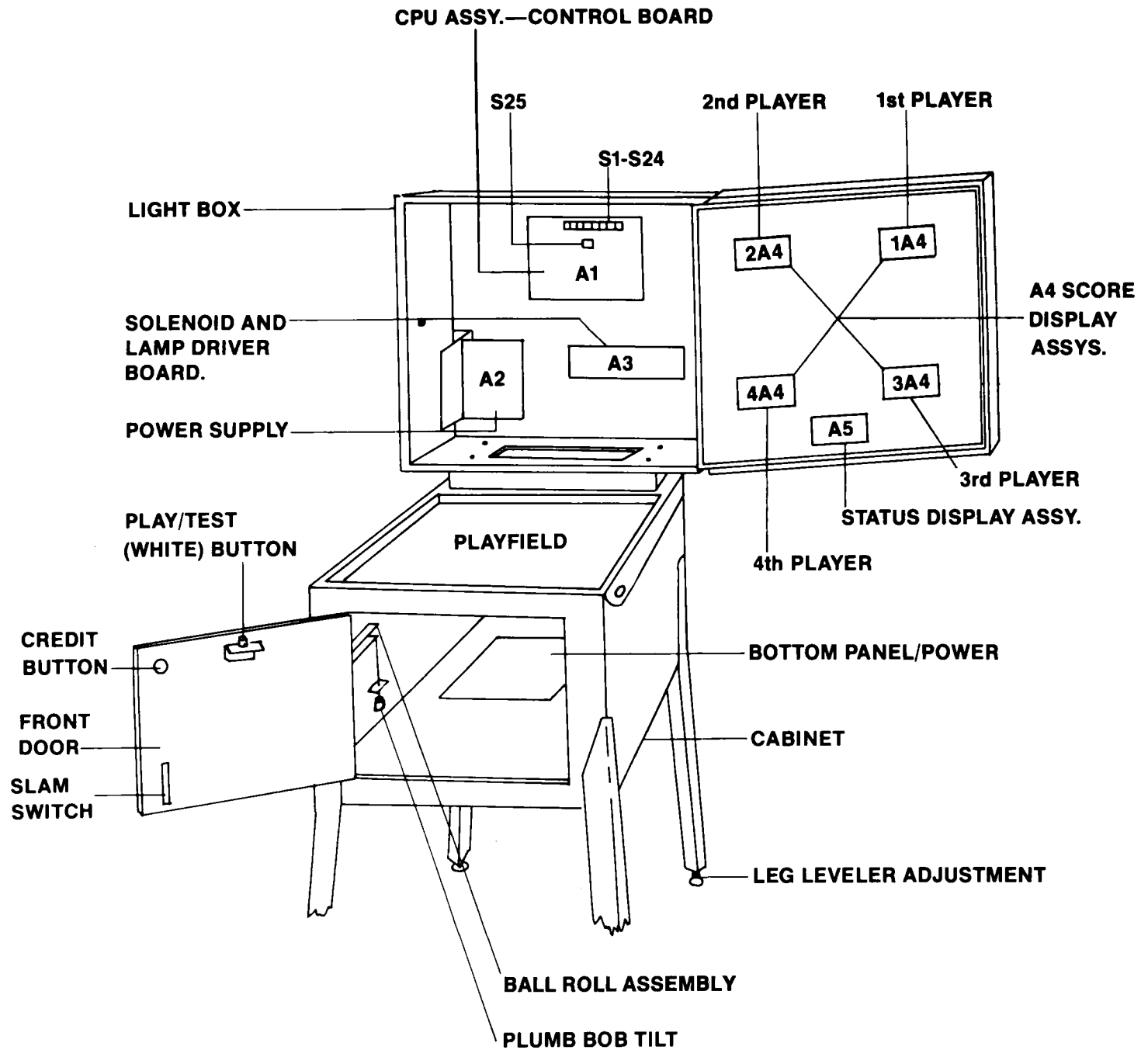

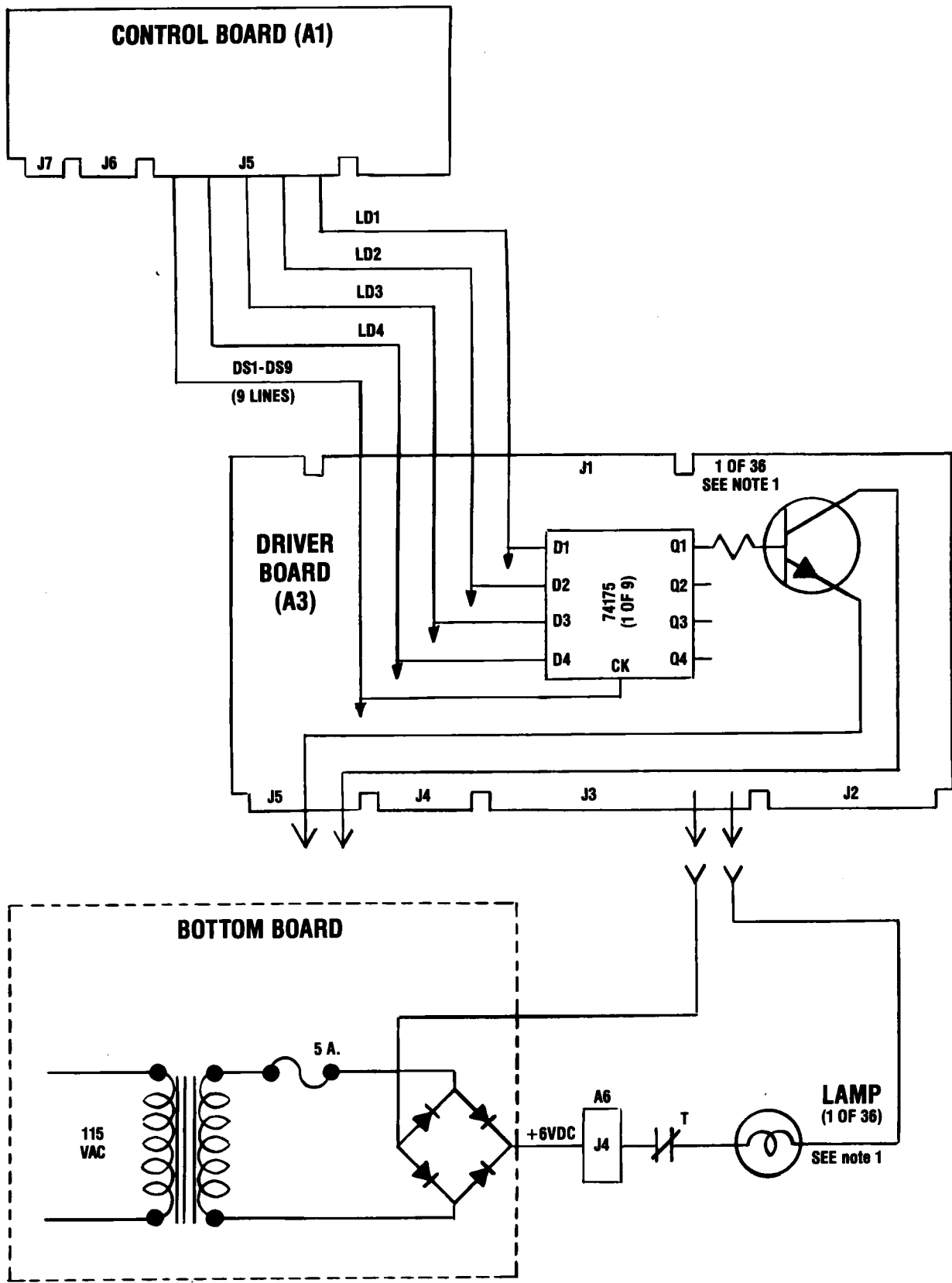

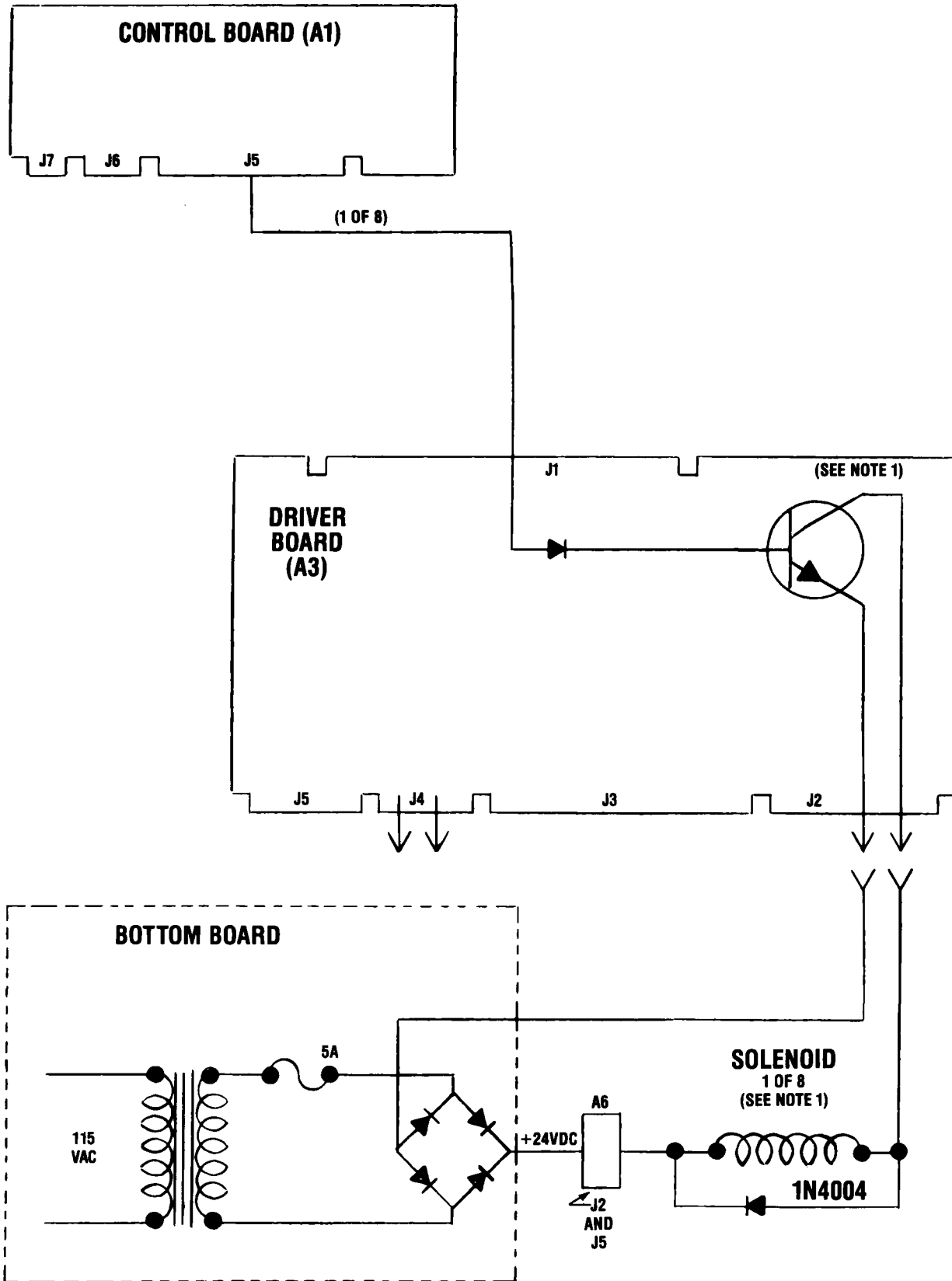

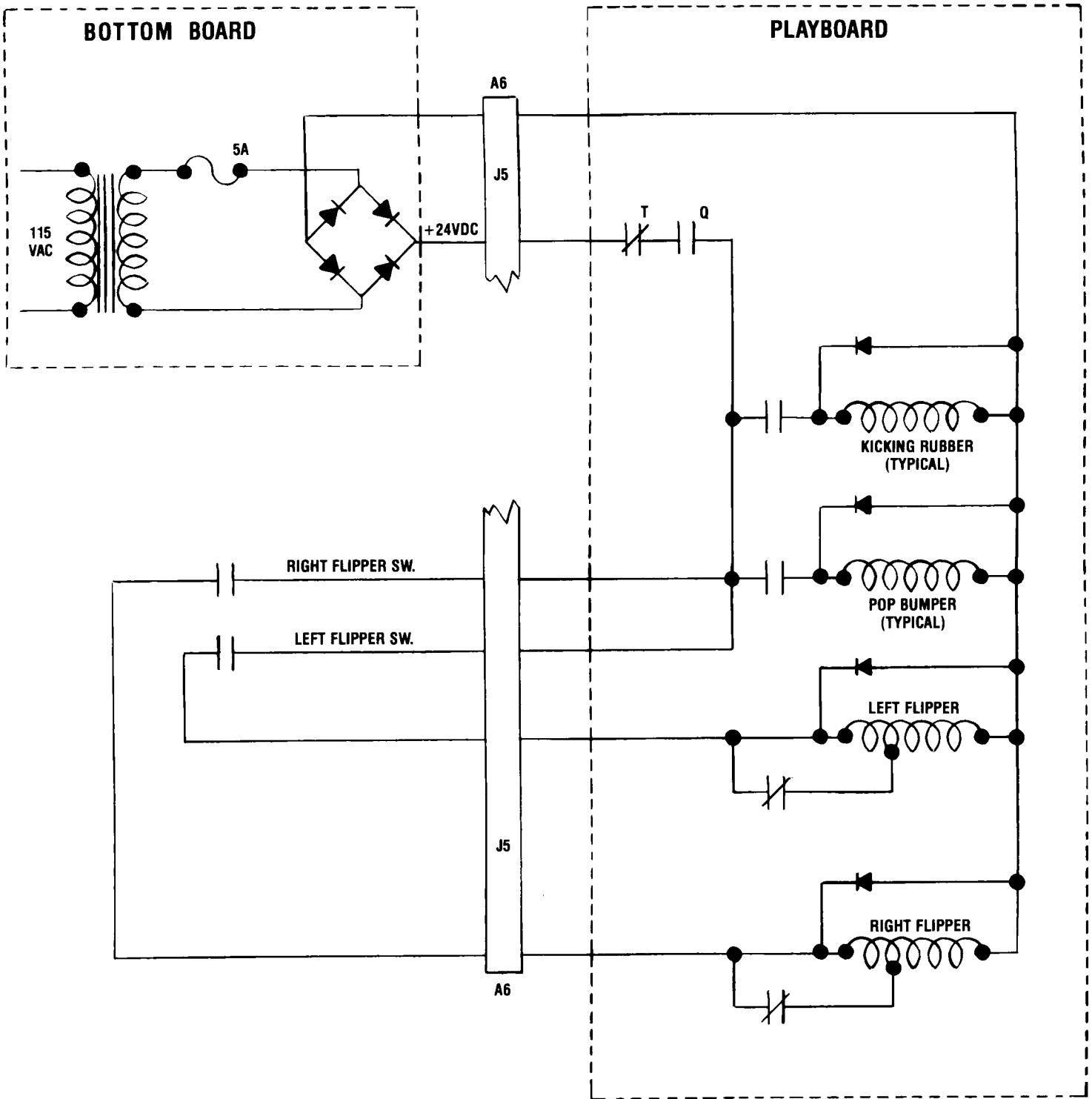

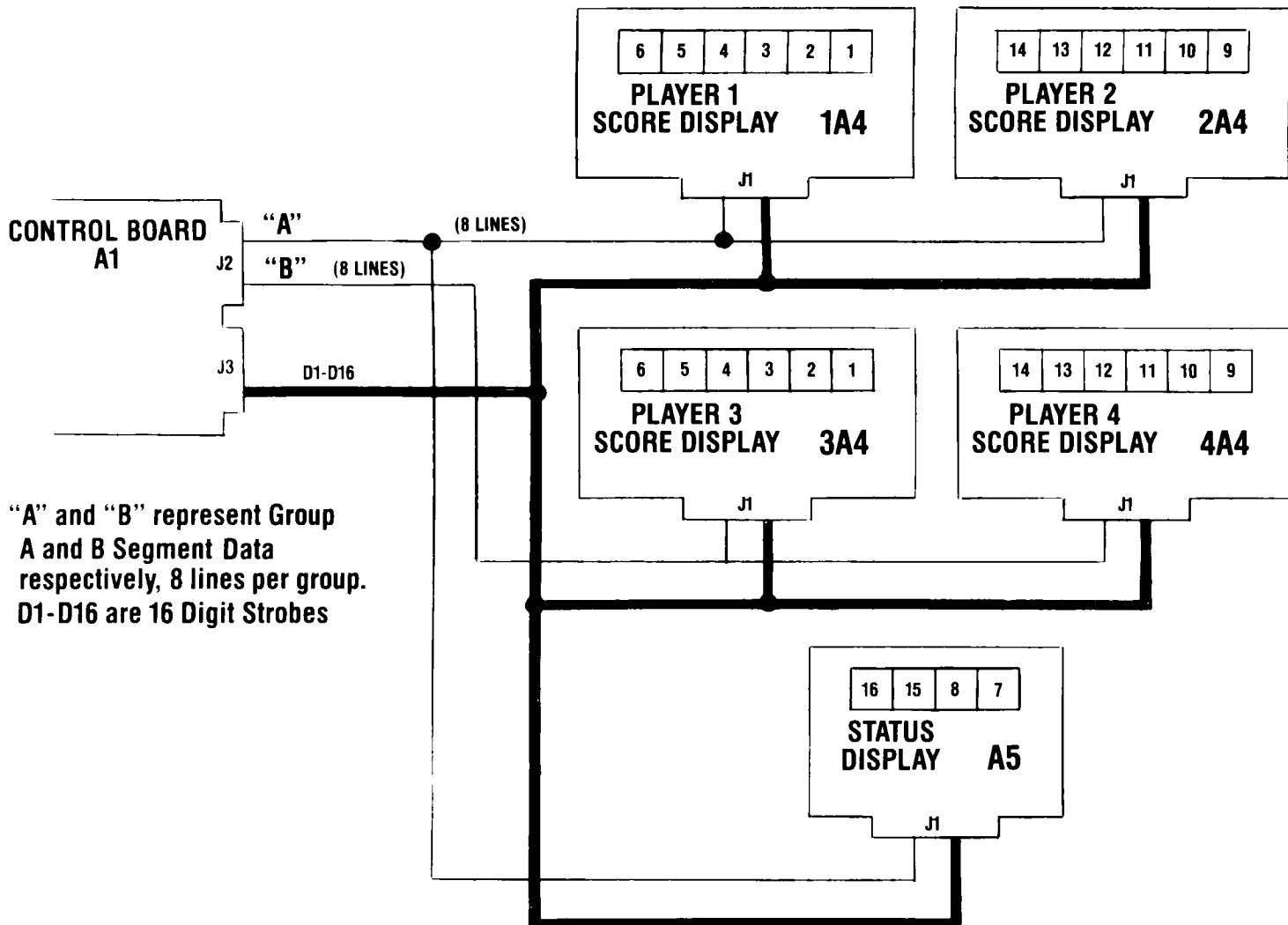

“A” and “B” represent Group A and B Segment Data respectively, 8 lines per group. D1-D16 are 16 Digit Strobes

NUMBER DISPLAYED	SEGMENTS USED							
	a	b	c	d	e	f	g	h
0	■	■	■	■	■	■	■	■
1	■	■	■	■	■	■	■	■
2	■	■	■	■	■	■	■	■
3	■	■	■	■	■	■	■	■
4	■	■	■	■	■	■	■	■
5	■	■	■	■	■	■	■	■
6	■	■	■	■	■	■	■	■
7	■	■	■	■	■	■	■	■
8	■	■	■	■	■	■	■	■
9	■	■	■	■	■	■	■	■

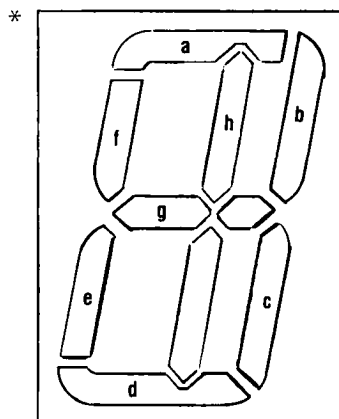

TYPICAL DIGIT

*NOTE: Display A5 does not have an “h” Segment, and the Number 1 is displayed utilizing Segments “b” and “c”.

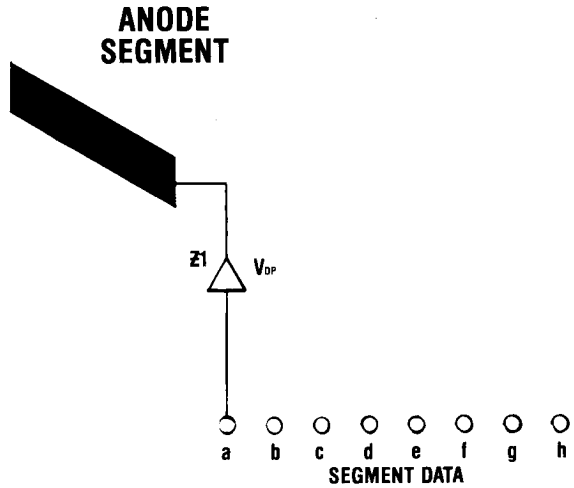
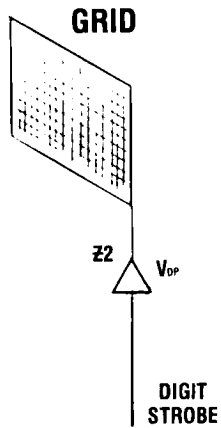
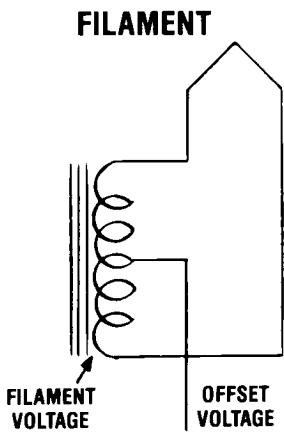
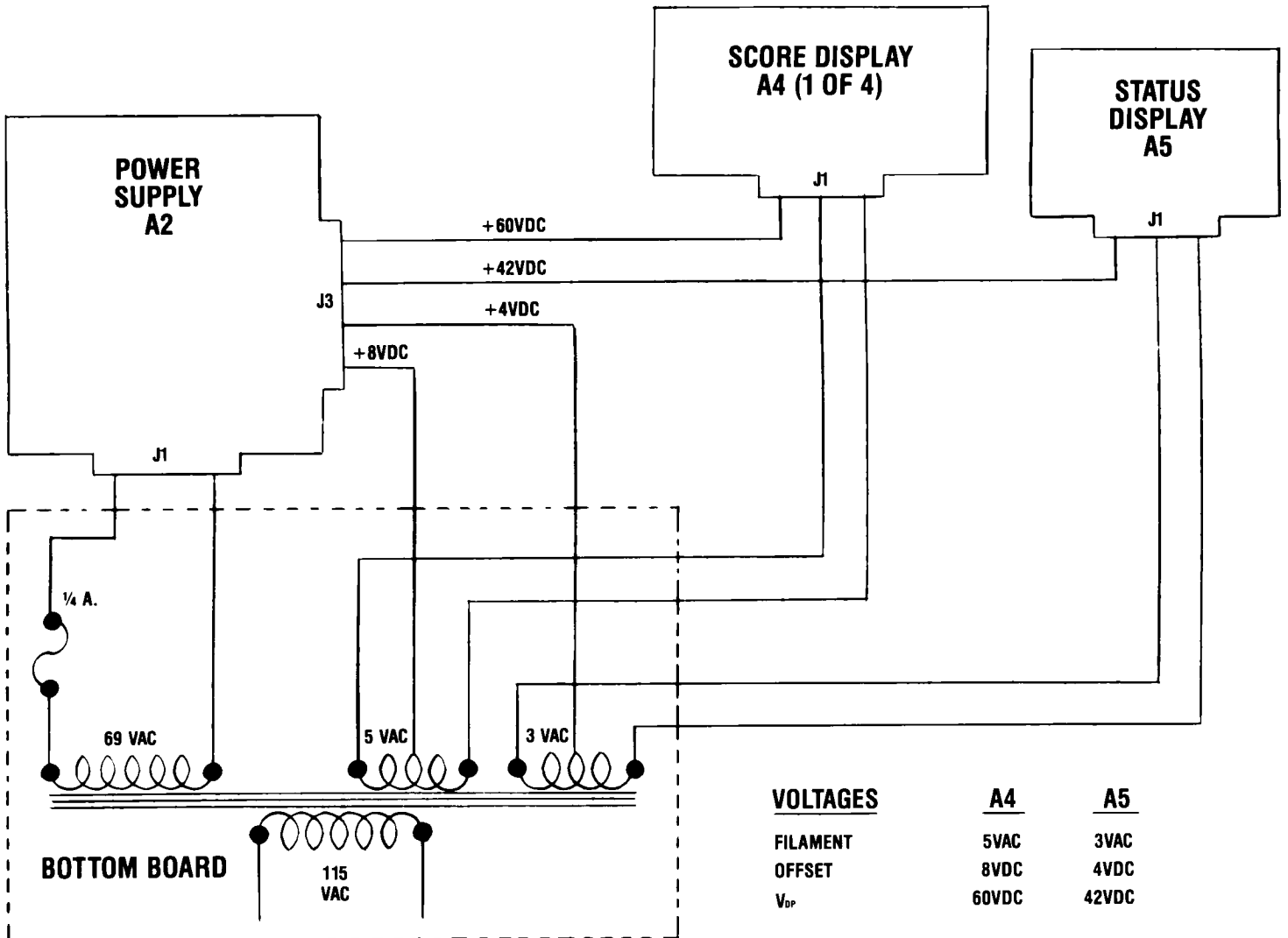

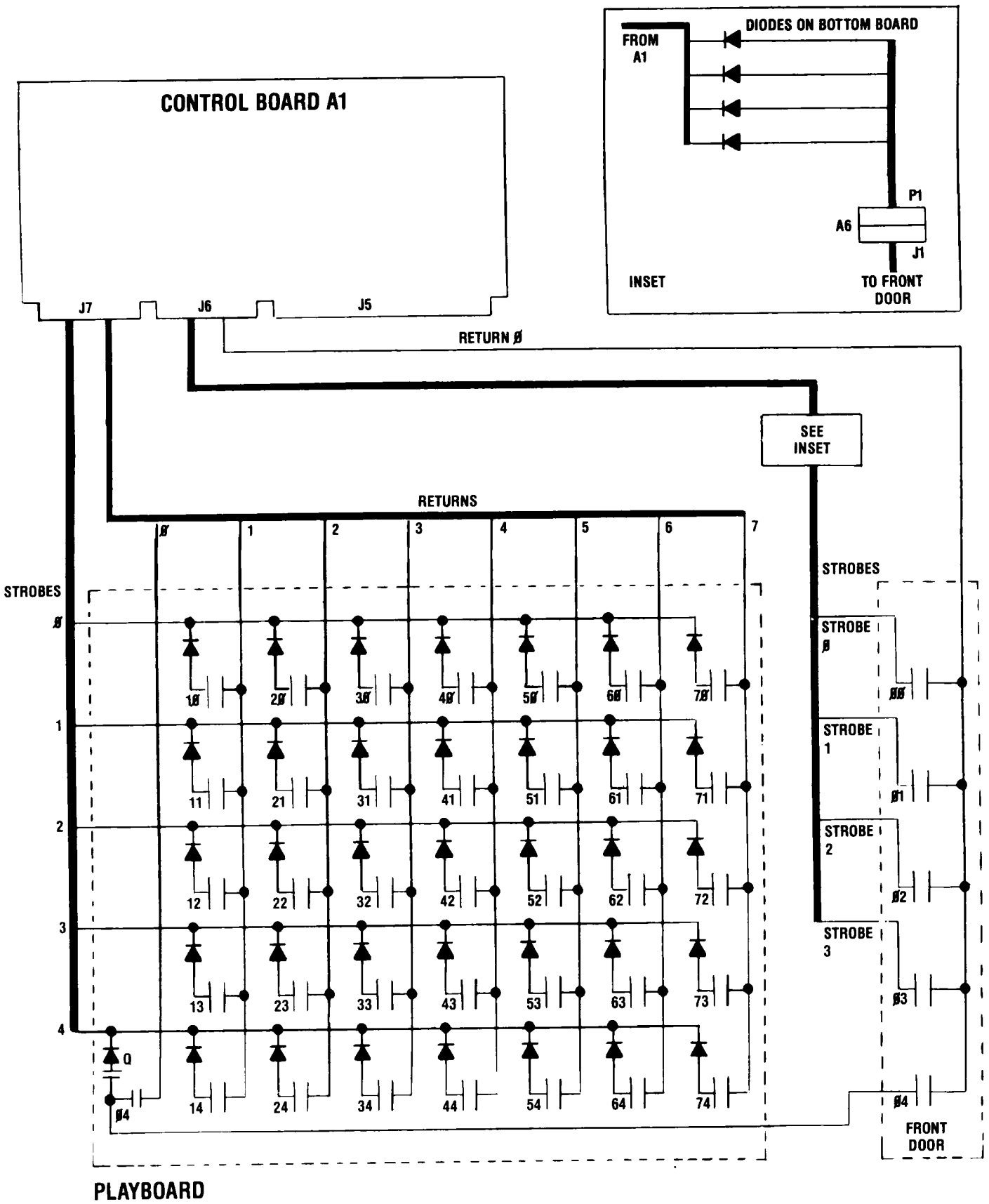

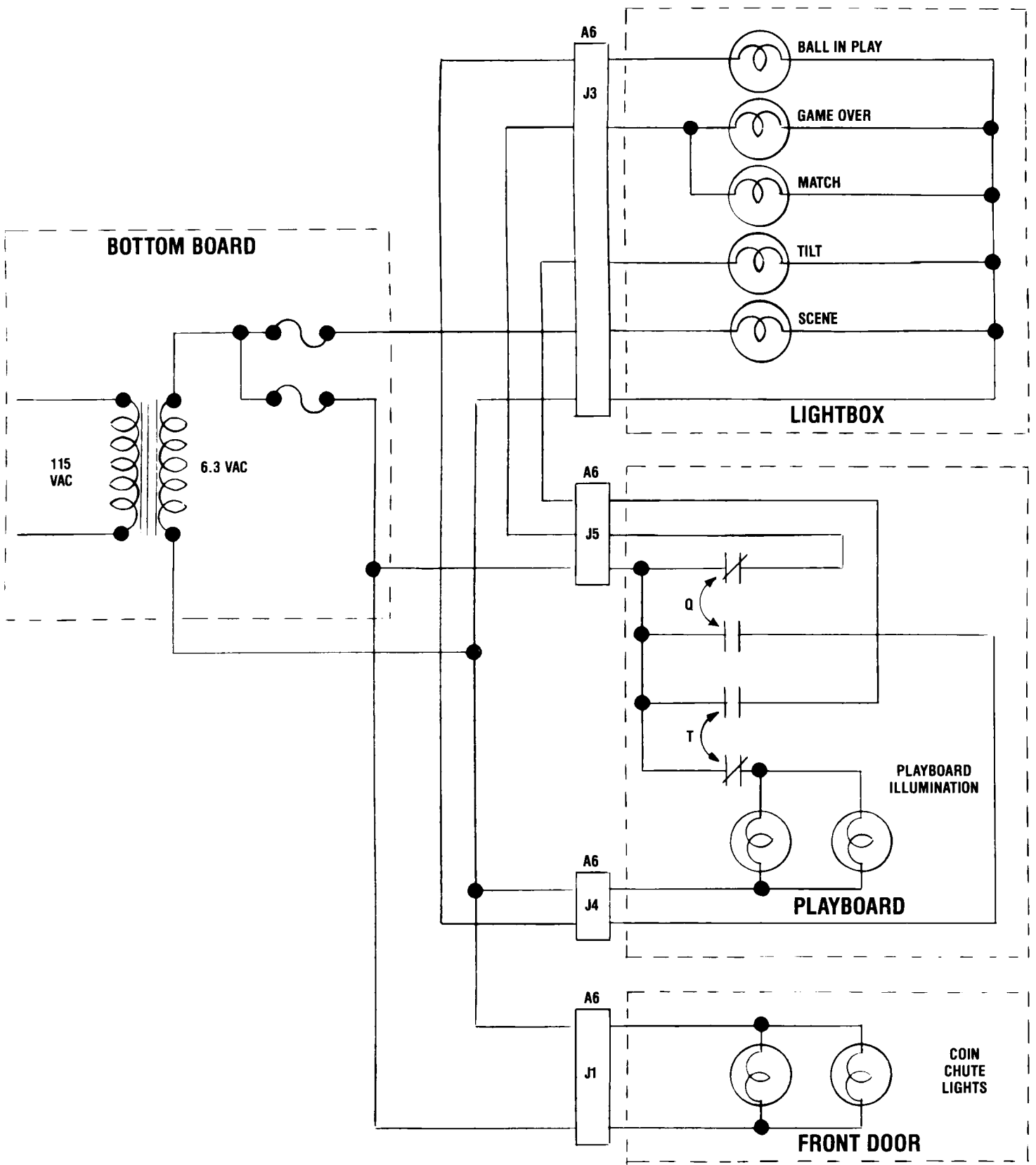

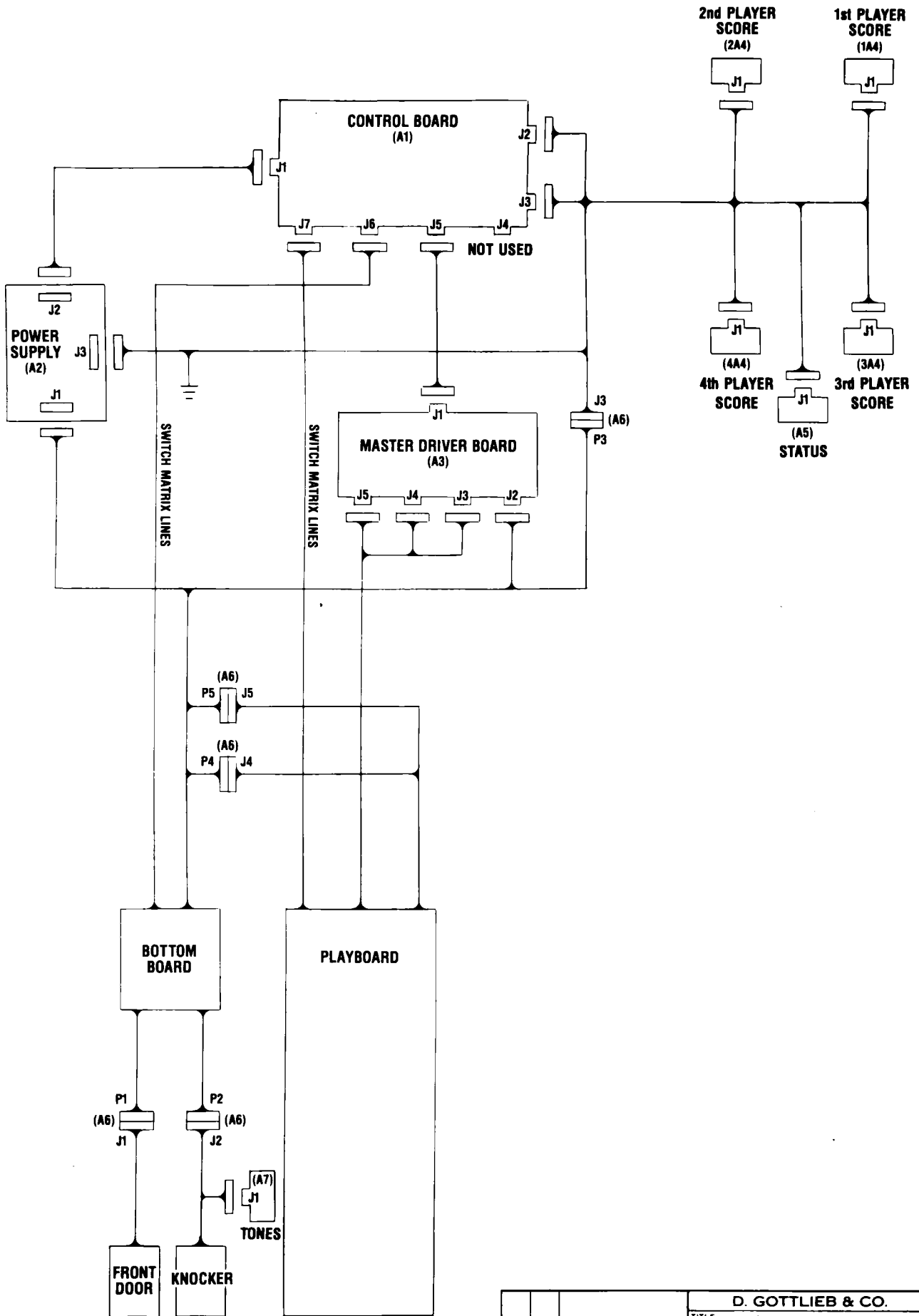

			D. GOTTLIEB & CO.		
			TITLE BLOCK CABLE DIAGRAM		
			USED ON SOLID STATE		
ISSUE	DATE	REVISIONS	DRAWN	APPROVED	DATE
					C-18012

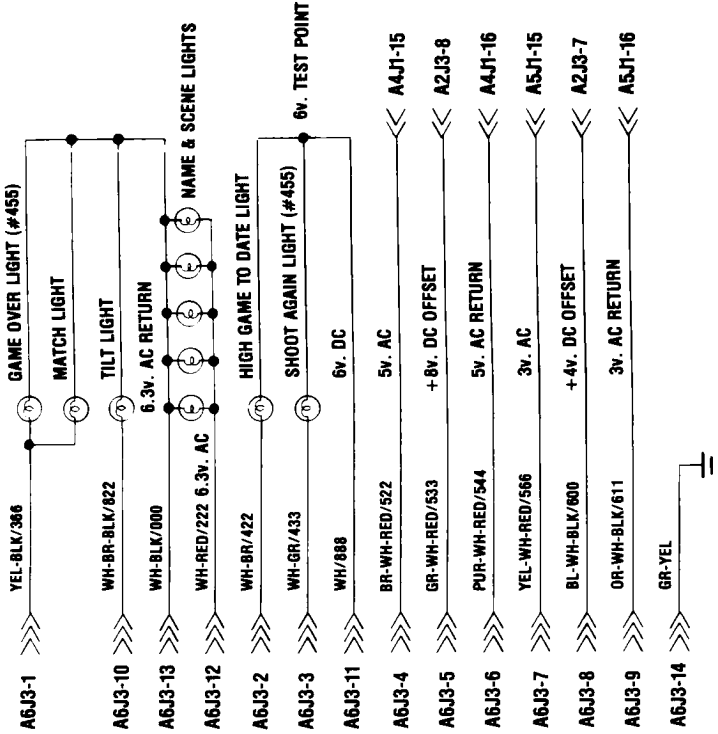
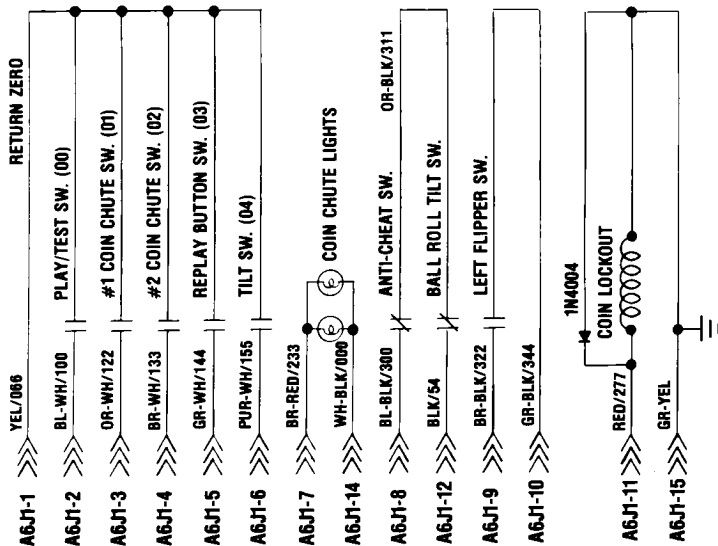

Note: The number after the wire color indicates a possible color change. The numbers correspond to a color as indicated in the color code chart.

Color Code Chart

0	Black
1	Brown
2	Red
3	Orange
4	Yellow
5	Green
6	Blue
7	Purple
8	Slate

**REFER TO
DRWG. B-18555
FOR GAMES
WITH SOUND**

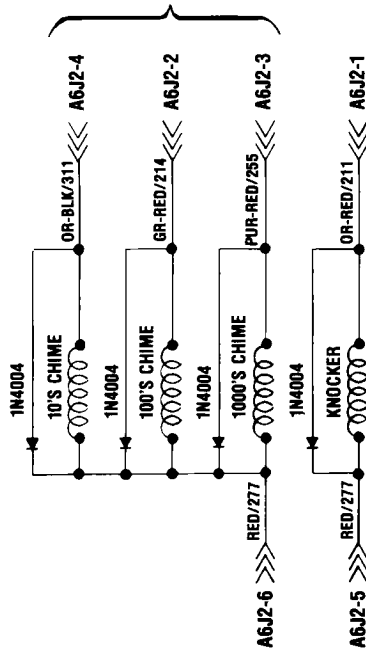

COILS USED

PART NO.	DESCRIPTION
A-17876	CHIME COILS
A-5195	KNOCKER COIL
A-16890	COIN LOCKOUT COIL

NOTE: > FROM PLAYBOARD

>> FROM LIGHT BOX

>>> FROM BOTTOM BOARD

D. GOTTLIEB & CO.	
TITLE	BOTTOM BOARD & LIGHT BOX
USED ON	SCHEMATIC
DRAWN	SOLID STATE
APPROVED DATE	
ISSUE DATE	REVISIONS
	C-18014

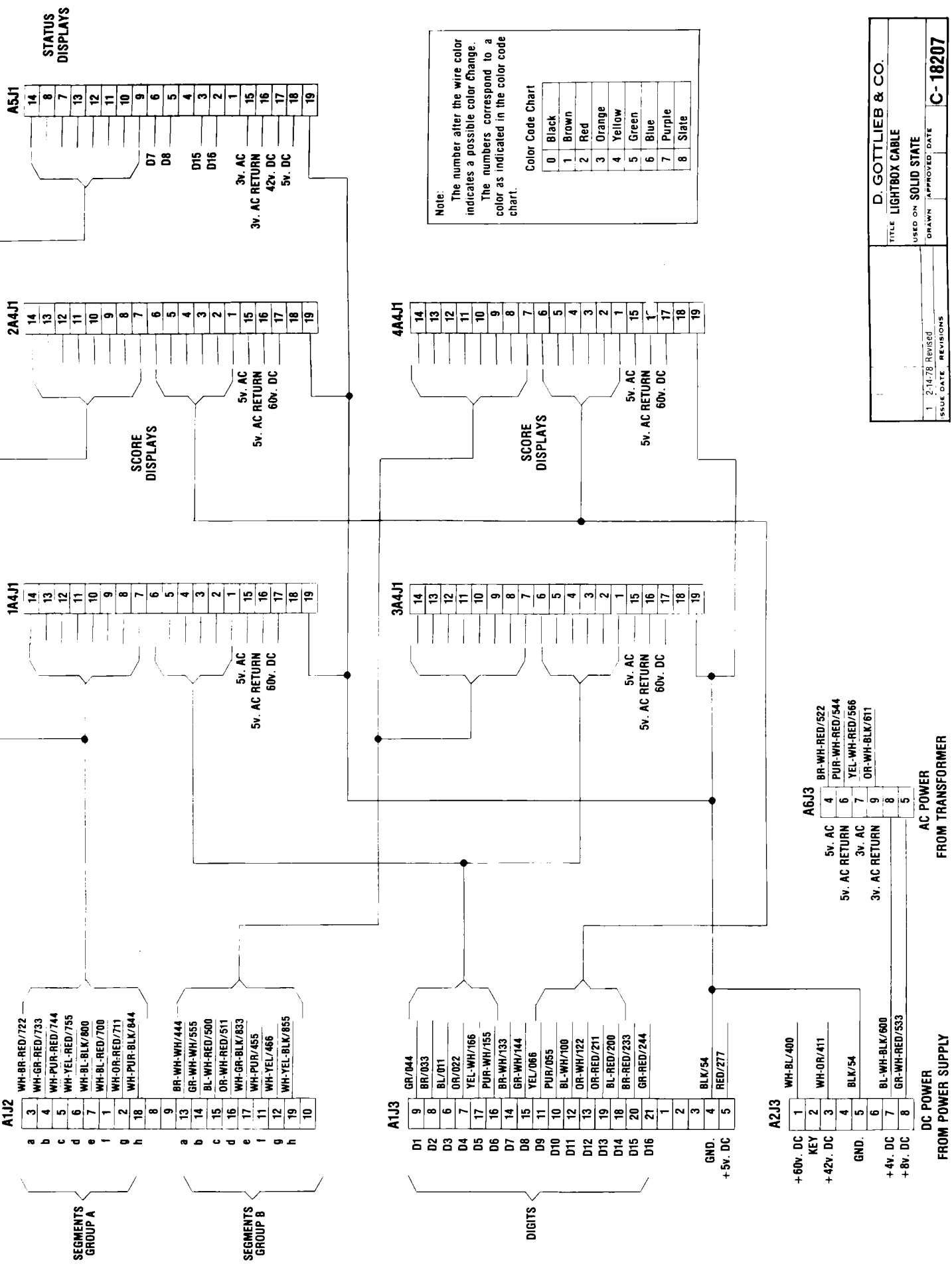

D. GOTTLIEB & CO.

TITLE: LIGHTBOX CABLE

USED ON: SOLID STATE

ISSUE DATE: 2-14-78

REVISIONS: 1

DRAWN: APPROVED: DATE:

C-18207

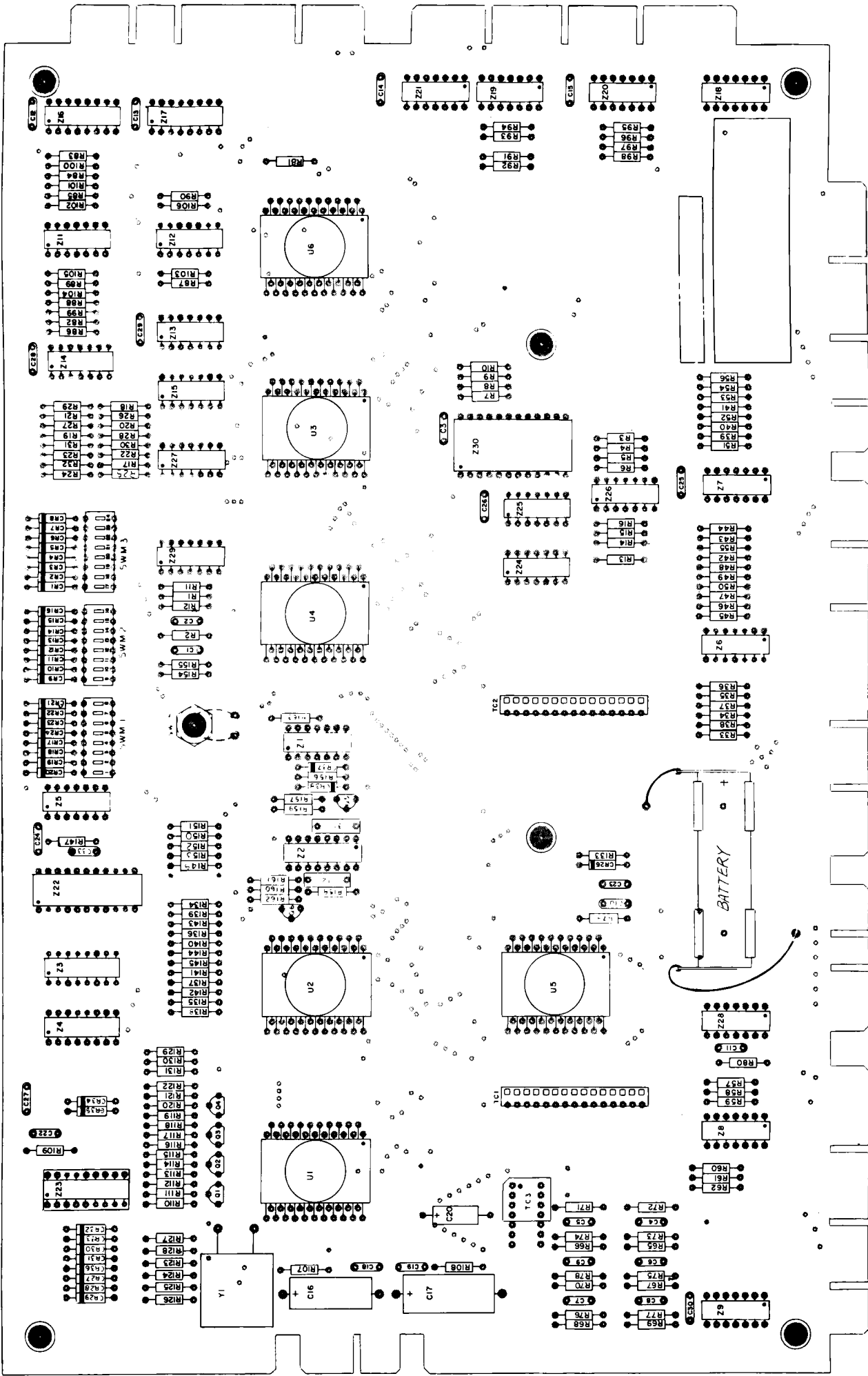

D. GOTTLIEB & CO.	
TITLE SCHEMATIC DIAGRAM-CONTROL BOARD	
USED ON	
ISSUE DATE	APPROVED DATE
1 / 2-78	REVISED
REVISIONS	PB00-D100

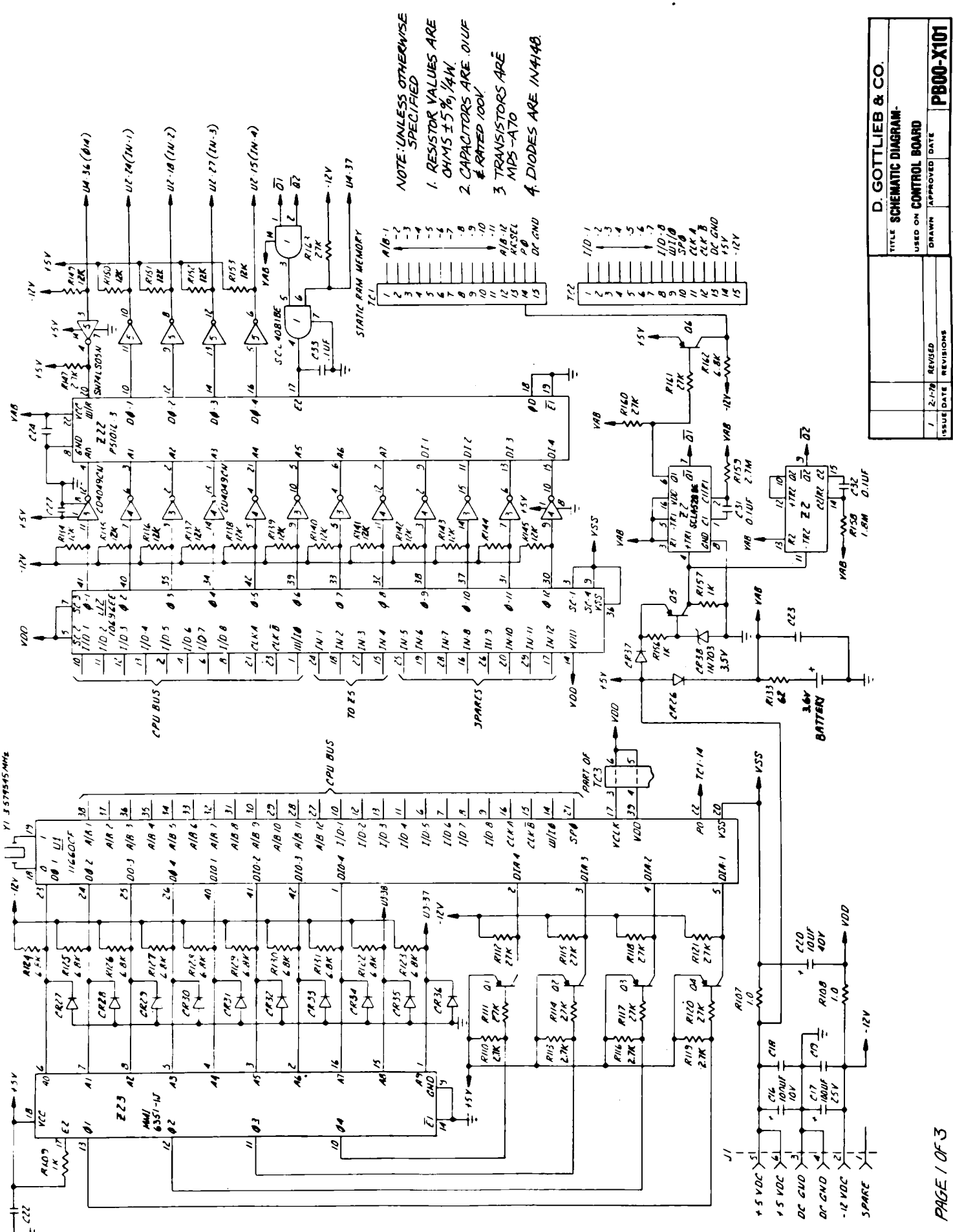

NOTE: UNLESS OTHERWISE SPECIFIED
 1. RESISTOR VALUES ARE OHMS ± 5% 1/4W
 2. CAPACITORS ARE 0.1UF & RATED 100V
 3. TRANSISTORS ARE MIP5-A70
 4. DIODES ARE IN4140

D. GOTTLIEB & CO.	
TITLE SCHEMATIC DIAGRAM	
USED ON CONTROL BOARD	
ISSUE DATE	APPROVED DATE
1 / 2 / 78	
REVISED	
REVISIONS	
P800-X101	

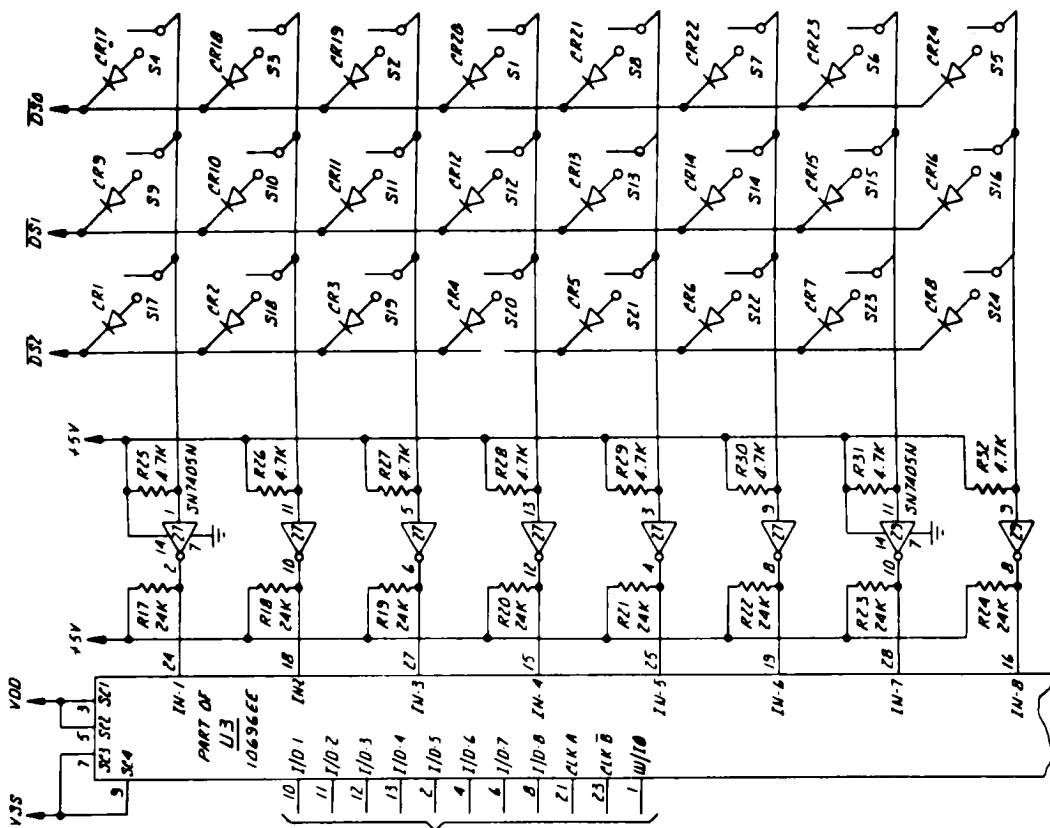

ADJUSTABLE PARAMETER MATRIX

LAMP & APM CONTROL

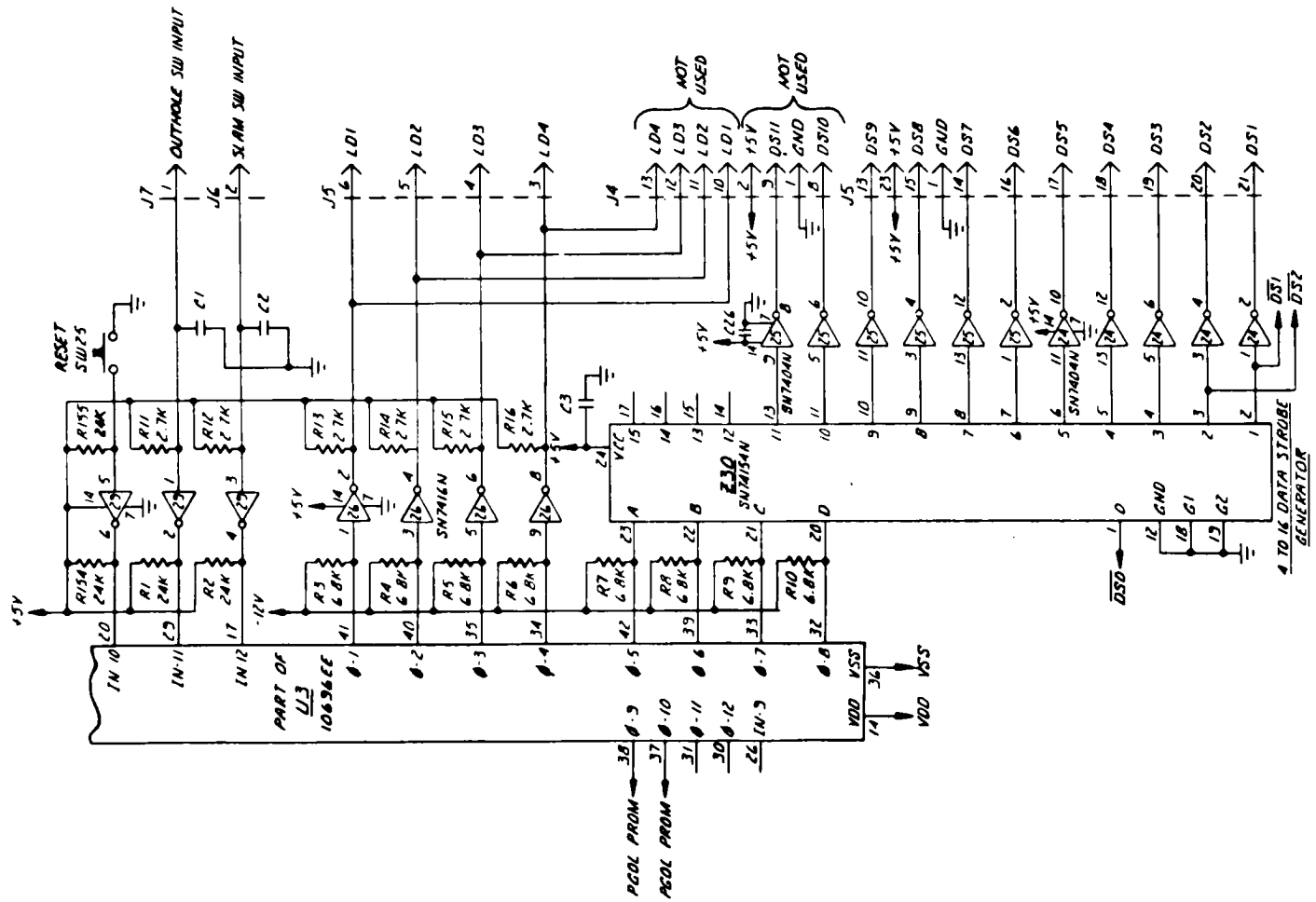

D. GOTTLIEB & CO.	
TITLE SCHEMATIC DIAGRAM-	
USED ON CONTROL BOARD	
1	2-78
ISSUE DATE	REVISED
	APPROVED DATE
	REVISIONS
	PB00-X101

NOTE:
 L5 TO L36 INDICATE LAMP ASSIGNMENT
 SEE LAMP ASSIGNMENT PAGE FOR DESCRIPTION.

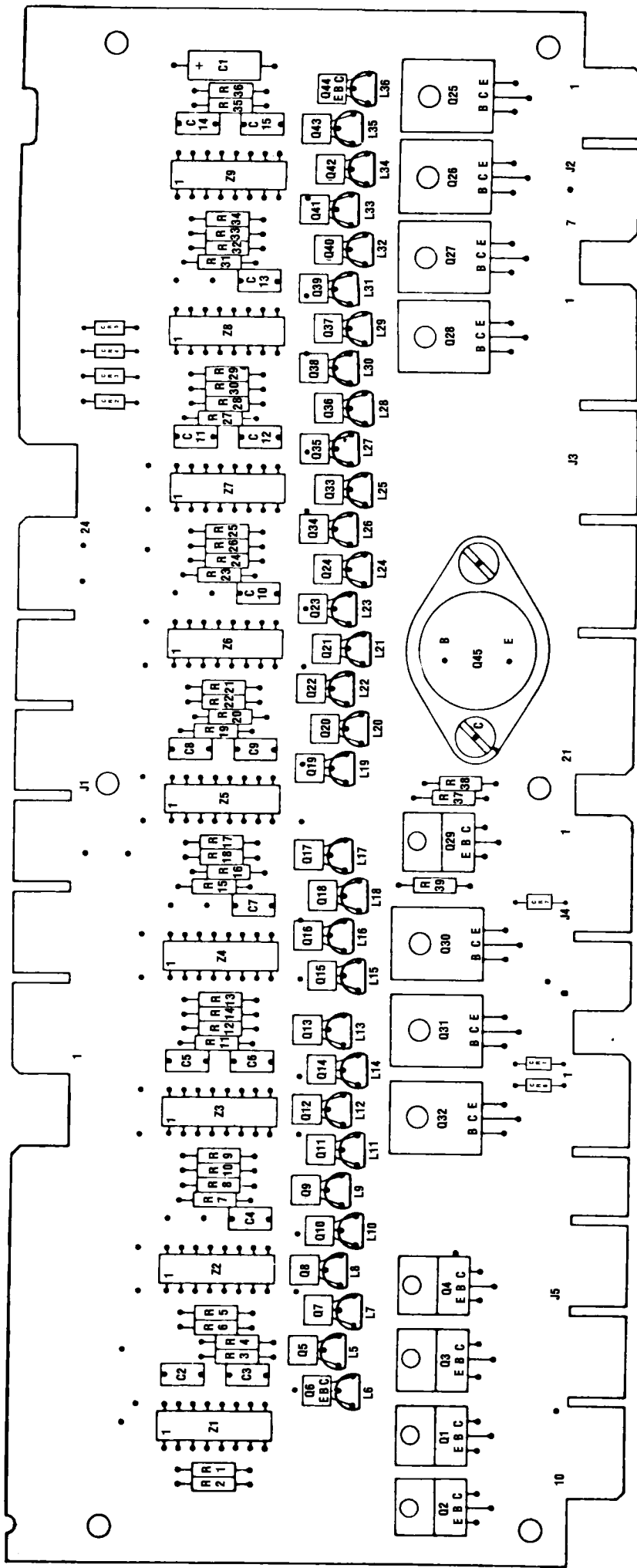

- Q1—GAME OVER RELAY
- Q2—TILT RELAY
- Q3—HIGH GAME TO DATE
- Q4—SHOOT AGAIN

- Q25—KNOCKER
- Q26—TENS
- Q27—HUNDREDS
- Q28—THOUSANDS

- Q29 & Q45—SOLENOID #8
- Q30—SOLENOID #7
- Q31—SOLENOID #6
- Q32—OUTHOLE

D. GOTTLIEB & CO.		TITLE	
		SCHEMATIC DIAGRAM - MASTER DRIVER	
USED ON		DATE	REVISIONS
1	5-78	REVISED	
DRAWN		APPROVED	DATE
			PB00-D110

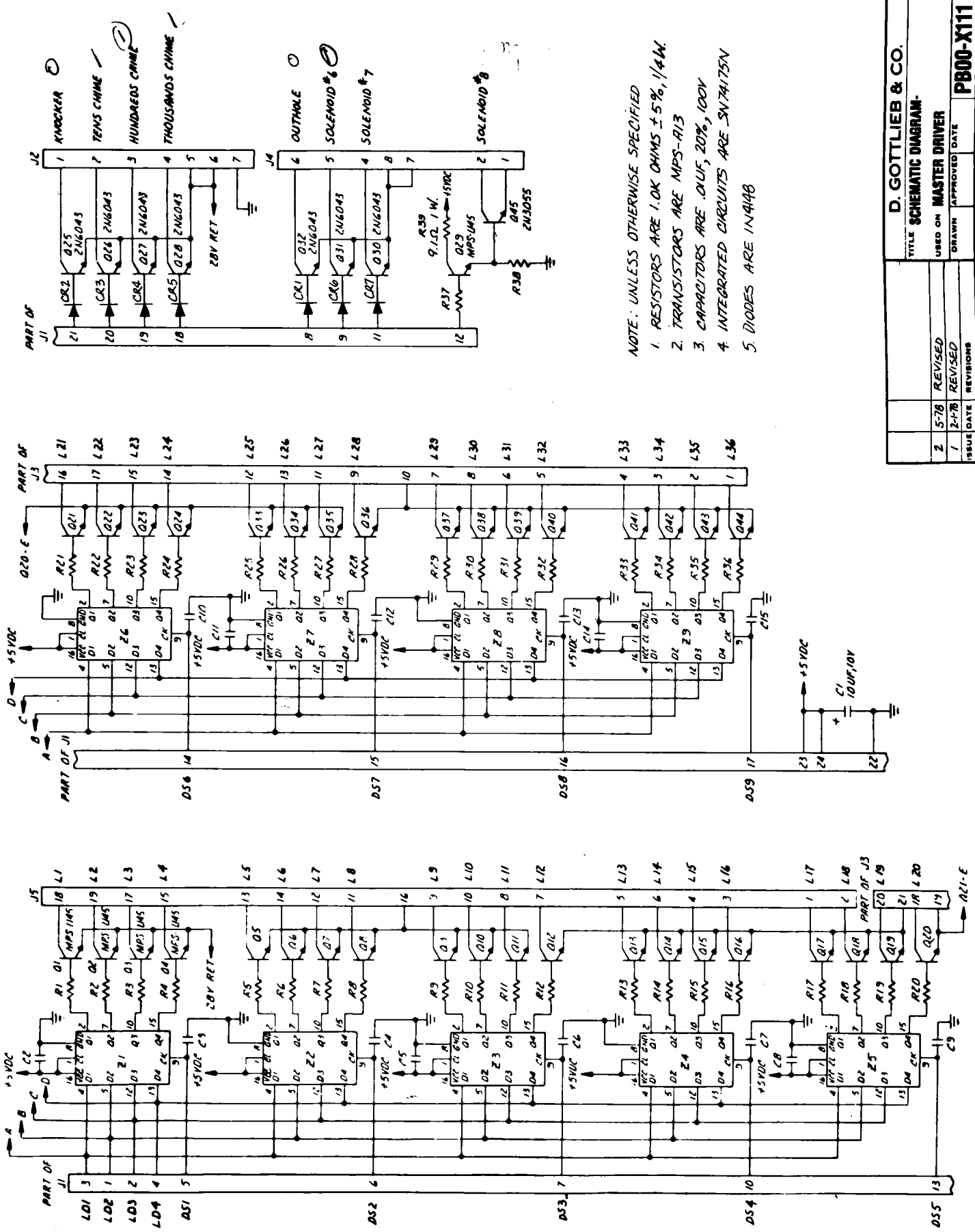

NOTE: UNLESS OTHERWISE SPECIFIED
 1. RESISTORS ARE 1.0K OHMS ± 5%, 1/4W.
 2. TRANSISTORS ARE MPS-R13
 3. CAPACITORS ARE .01UF, 20%, 100V
 4. INTEGRATED CIRCUITS ARE SN74175N
 5. DIODES ARE 1N4148

D. GOTTLIEB & CO.	
TITLE SCHEMATIC DIAGRAM-	
USED ON MASTER DRIVER	
ISSUE	REVISIONS
2	5-78 REVISED
1	2-78 REVISED
DATE	APPROVED DATE
	DRAWN
	PB00-X111

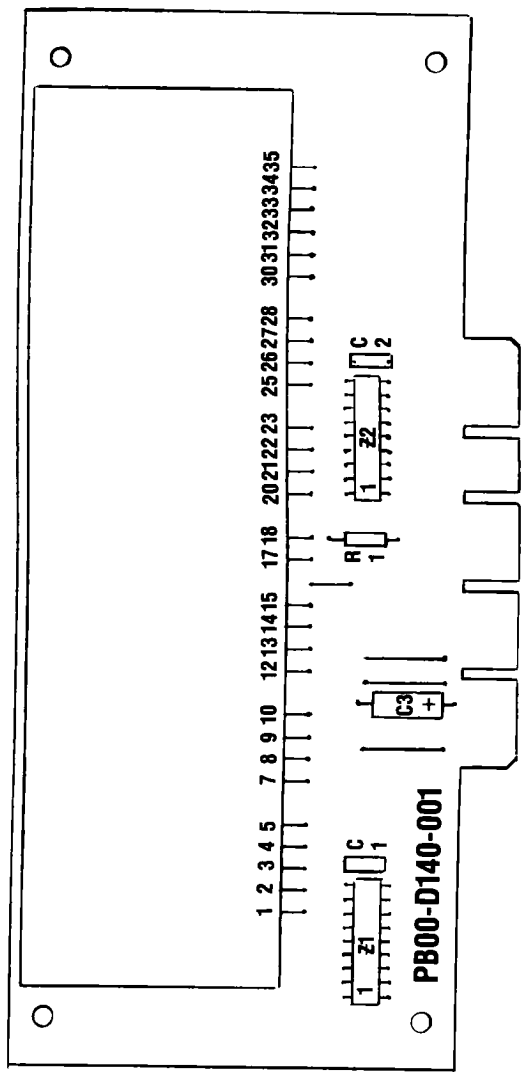
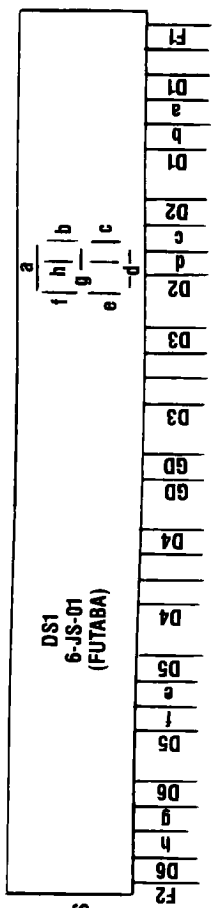
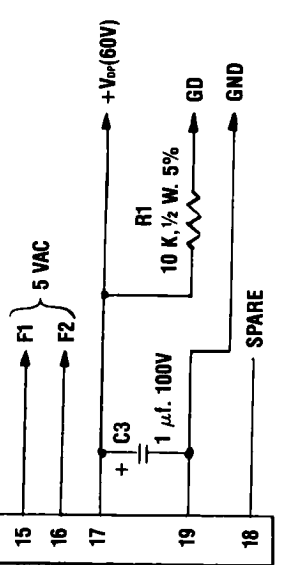
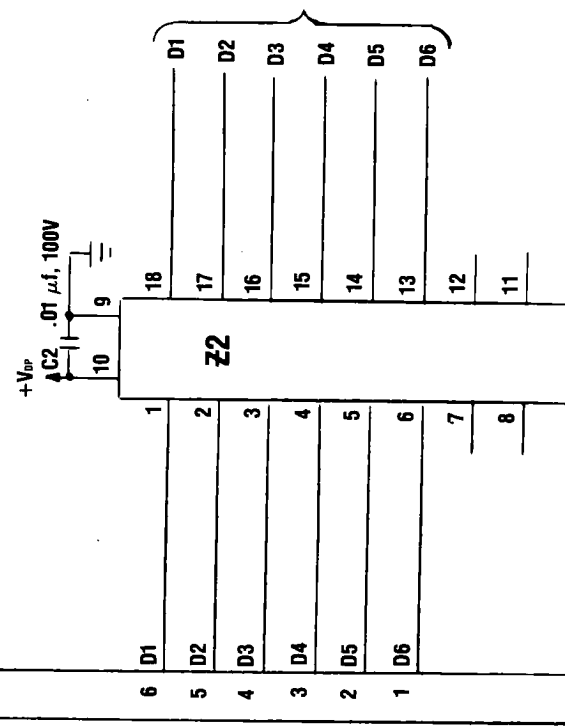
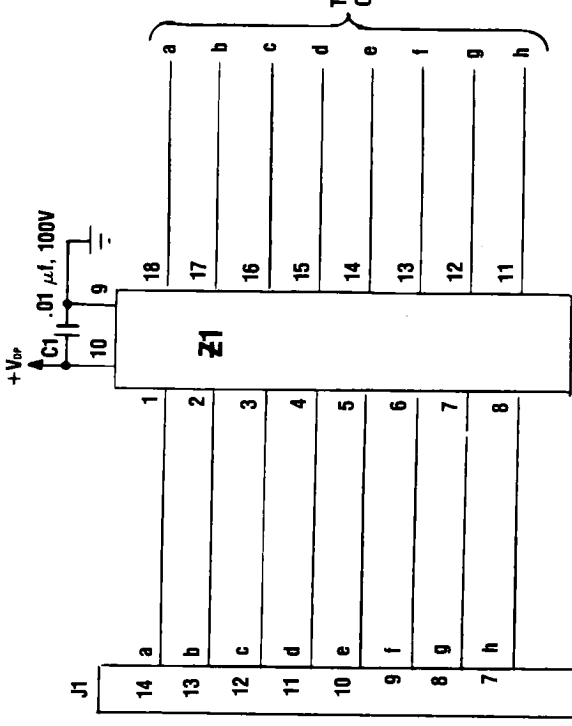

NOTE: Z1 & Z2 ARE UDN6118A (SPRAGUE)

D. GOTTLIEB & CO.	
TITLE SCHEMATIC DIAGRAM —	
USED ON SPRAGUE DRIVER	
ISSUE DATE	REVISIONS
1 / 2-7-78	REVISED
	APPROVED DATE
	PB00-D140

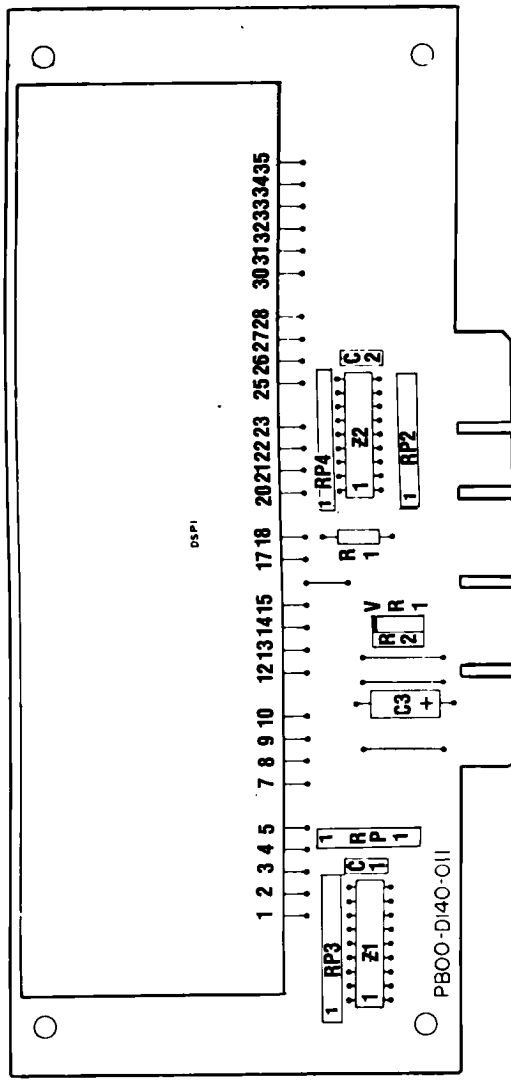
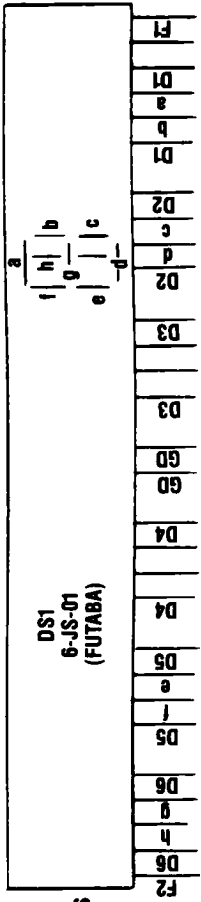
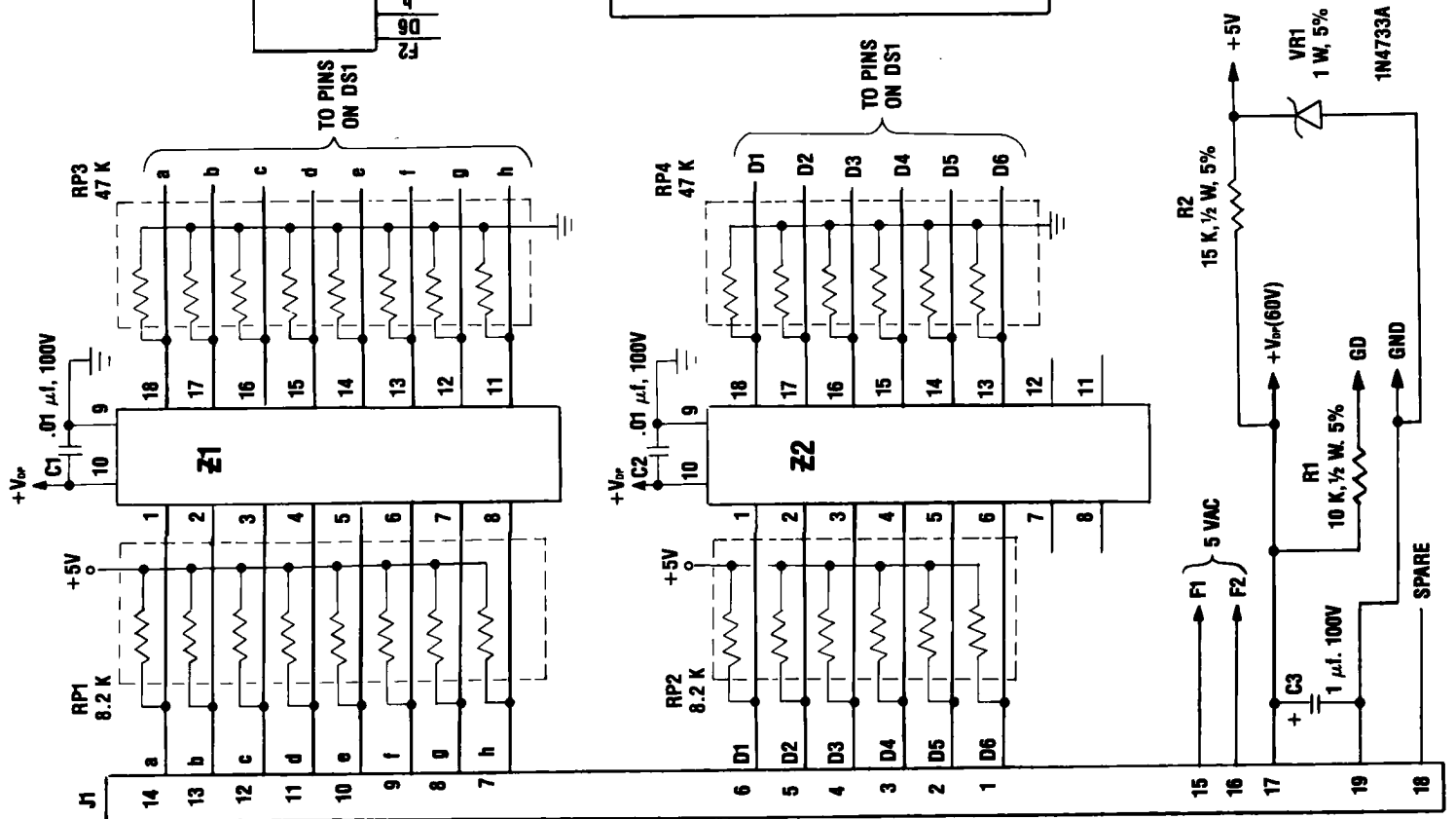

NOTE: UNLESS OTHERWISE SPECIFIED

1. Z1 & Z2 ARE DI513 (dionics) -11 ONLY
2. RP1, RP2, RP3, RP4, R2 & VR1 ARE USED ON -11 ASS'Y ONLY.

D. GOTTLIEB & CO.	
TITLE SCHEMATIC DIAGRAM—	
USED ON 6 DIGIT DISPLAY	
2	5-78 REVISED
1	2-78 REVISED
ISSUE/DATE	REVISIONS
	PB00-D140

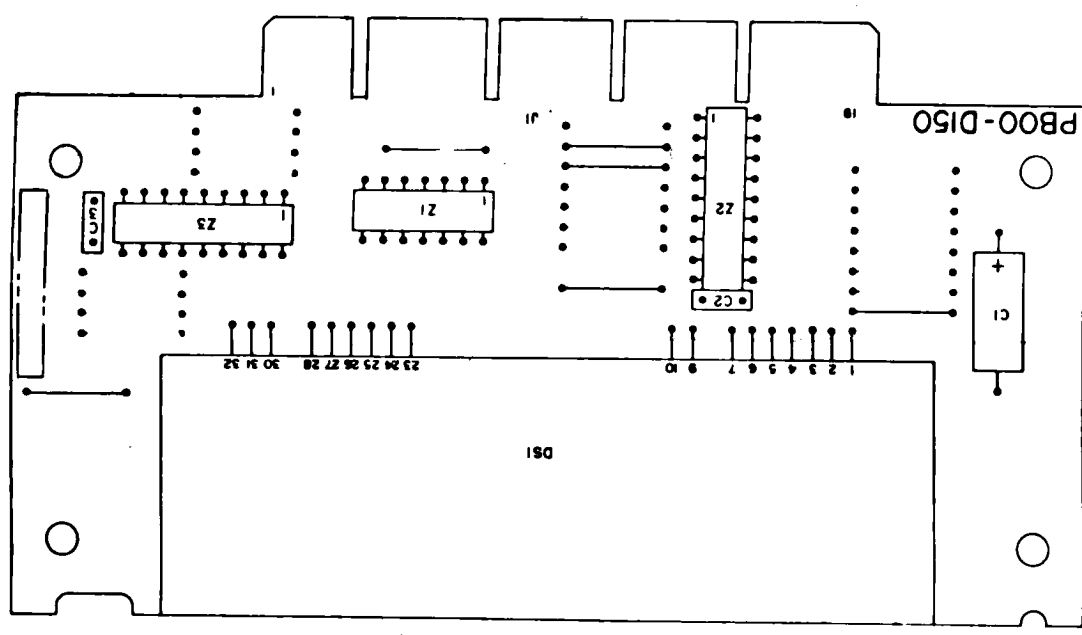
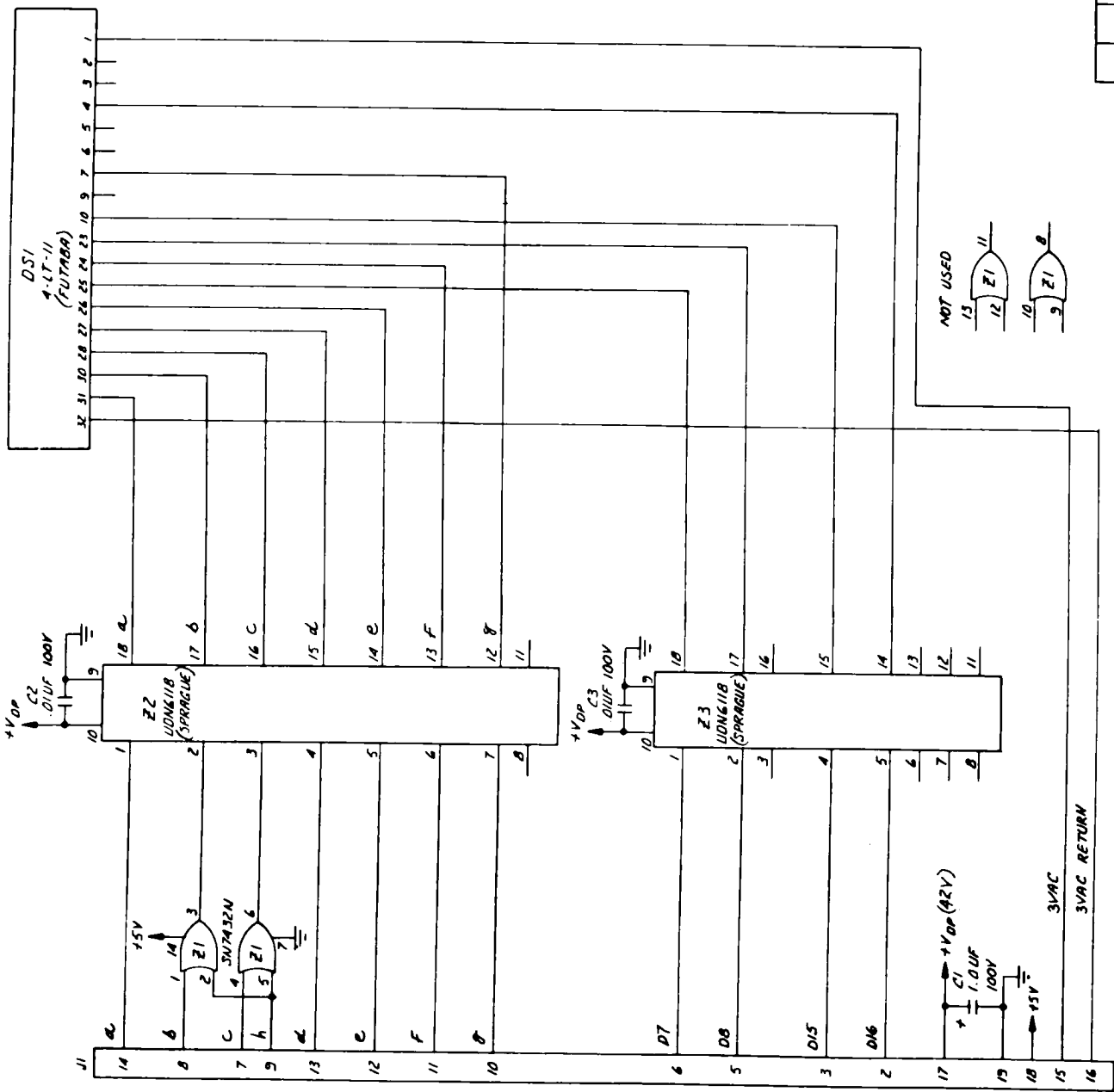

NOTE:
RESISTOR VALUES ARE IN
OHMS ±5%, 1/4 W

D. GOTTLIEB & CO.	
TITLE SCHEMATIC DIAGRAM-	
USED ON 4 DIGIT DISPLAY	
ISSUE DATE	REVISED REVISIONS
1 2-78	
DRAWN	APPROVED DATE
PB00-D150	

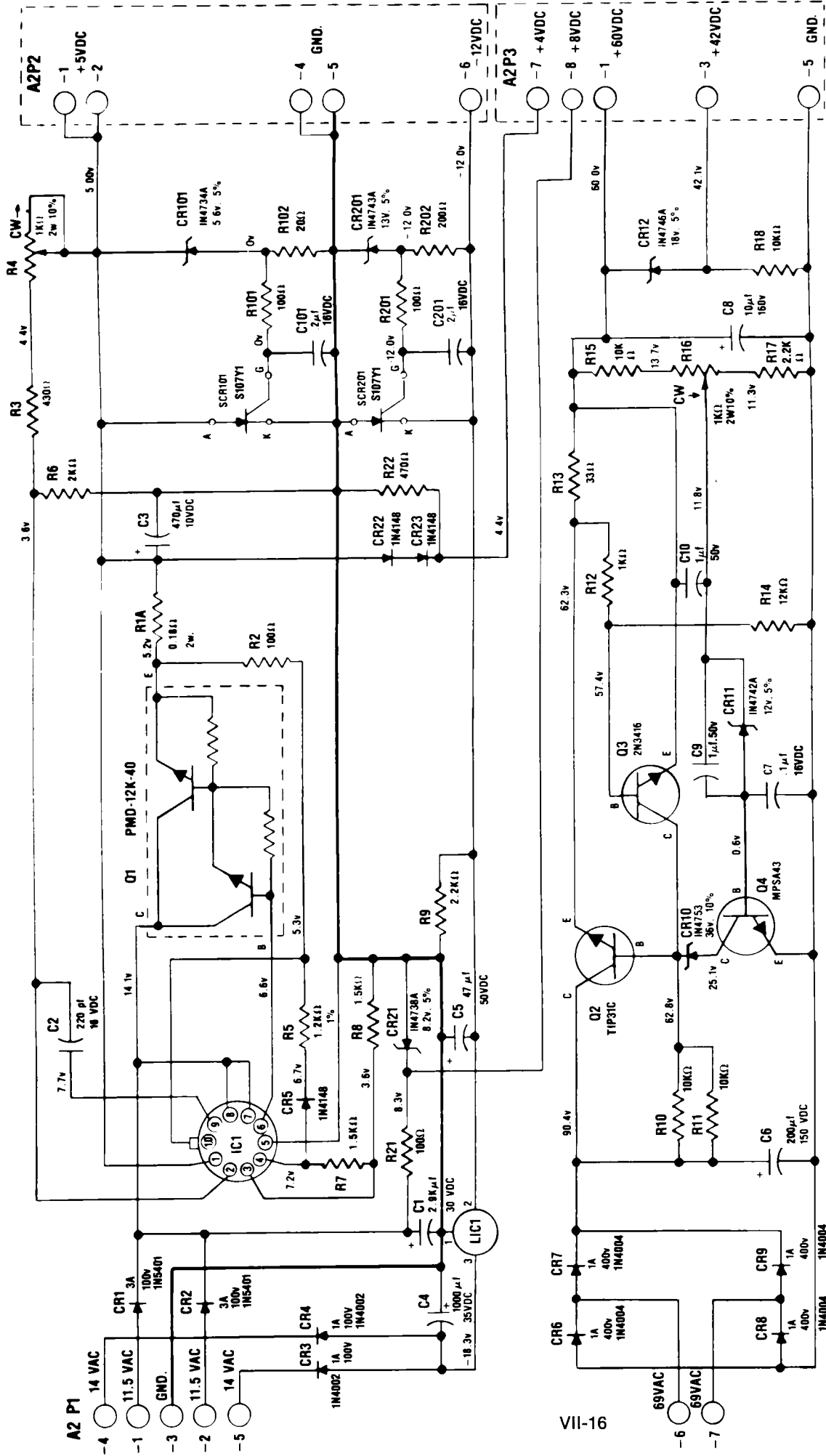

CR1, CR2 WAS MR751, CR5, CR22, CR23 WAS IN914, R21 WAS 680, R17 WAS 2.4K, R10-R11 WAS 15K, ADDED C9, C10		
4	6-78	Revised
3	2-1-78	Revised
2	1-18-78	Added Voltages
1	1-16-78	R13 WAS 56 Ω
ISSUE/DATE	REVISIONS	

D. GOTTLIEB & CO	
POWER SUPPLY SCHEMATIC	
USED ON	SOLID STATE GAME
DESIGNED BY	R.H.M.
APPROVED DATE	1-9-78
B-18396	

NOTE: UNLESS OTHERWISE SPECIFIED
 1. RESISTORS ARE 1/2 W. ± 5%
 2. VOLTAGES ARE DC AND WITH RESPECT TO GROUND.
 3. ALL VOLTAGES ARE TYPICAL.

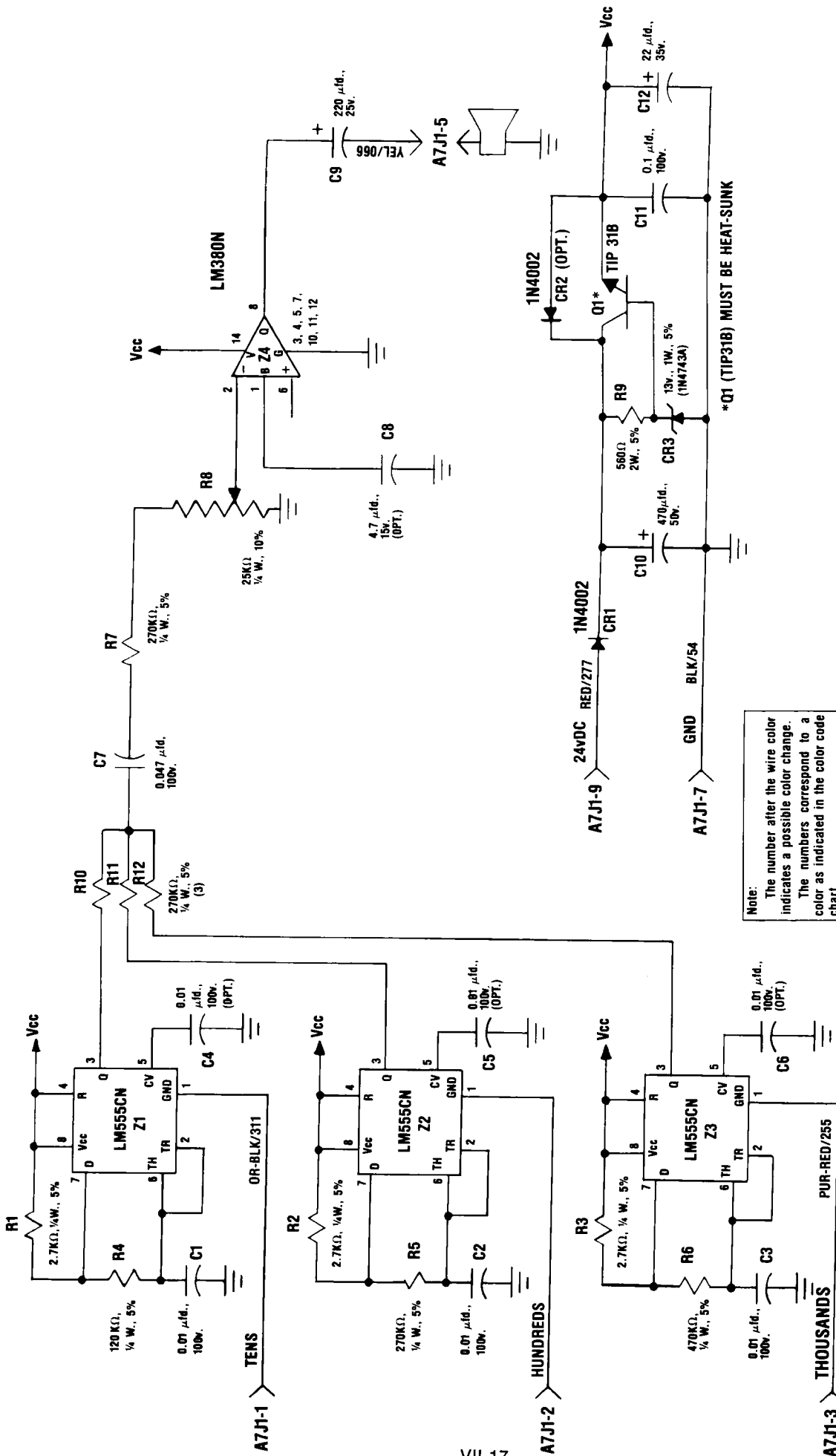

D. GOTTLIEB & CO.	
TITLE	SYNTHESIZED TONES
USED ON	
DRAWN	APPROVED DATE
ISSUE DATE	REVISIONS
3	2-1-78 Revised
2	1-18-78 Added Voltages
1	1-16-78 R13 Was 56Ω
B-18555	